

spirax sarco

Cast Iron Float & Thermostatic Steam Traps FT-15, FT-30, FT-75, FT-125

The trap contains a float valve mechanism which modulates to discharge condensate continuously at steam temperature, while non-condensable gases are released by a separate internal balanced pressure thermostatic air vent.

Model	FT-15	FT-30	FT-75	FT-125
PMO	15 psig	30 psig	75 psig	125 psig
Sizes	3/4", 1", 1-1/4", 1-1/2", 2"			
Connections	NPT			
Construction	Cast Iron Body & Cover Stainless Steel Internals			
Options	Gauge Glass, Vacuum Breaker			

Typical Applications

All process equipment, particularly when controlled by modulating temperature control valves; unit heaters, air heating coils, heat exchangers and steam main drip stations.

**For Capacities,
See TIS 2.317**

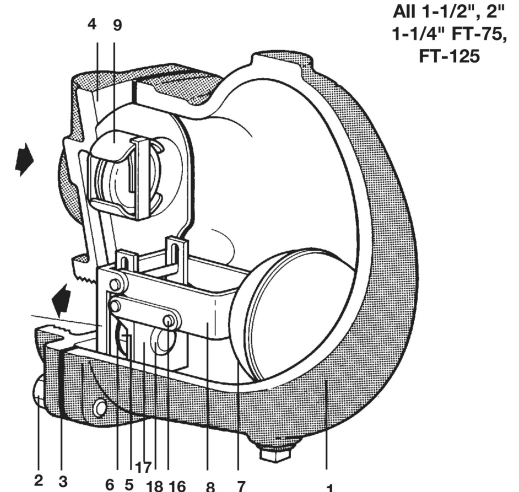
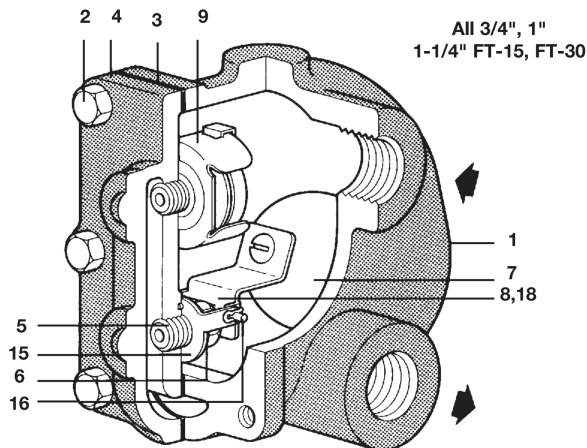

Limiting Operating Conditions

Max. Operating Pressure (PMO)

FT-15:	15 psig	(1.0 barg)
FT-30:	30 psig	(2.1 barg)
FT-75:	75 psig	(5.2 barg)
FT-125:	125 psig	(8.6 barg)

Max. Operating Temperature 450°F (25°C) at all operating pressures

Pressure Shell Design Conditions

PMA 125 psig/up to 450°F 9 barg/up to 232°C
Max. allowable pressure

TMA 450°F/0-125 psig 232°C/0-9 barg
Max. allowable temperature

Construction Materials

No.	Part	Material	
1	Body	Cast Iron	ASTM A126 CL B
2	Cover Screws	Carbon Steel	ASTM A449
3	Cover Gasket	Graphite	
4	Cover	Cast Iron	ASTM A126 CL B
5	Valve Seat	Stainless Steel	
6	Valve Seat Gasket	Stainless Steel	
7	Ball Float	Stainless Steel	
8	Float Arm	Stainless Steel	
9	Air Vent Assembly	Stainless Steel	
	Air Vent Head	Stainless Steel	
	Air Vent Seat	Stainless Steel	
15	Seat Bracket	Stainless Steel	
16	Pivot Pins	Stainless Steel	
17	Head Bracket, Stop, Link	Stainless Steel	
18	Valve Head	Stainless Steel	

*Local regulation may restrict the use of this product below the conditions quoted. Limiting conditions refer to standard connections only.
In the interests of development and improvement of the product, we reserve the right to change the specification.*

TI-2-313-US 2.14

Cast Iron Float & Thermostatic Steam Traps

FT-15, FT-30, FT-75, FT-125

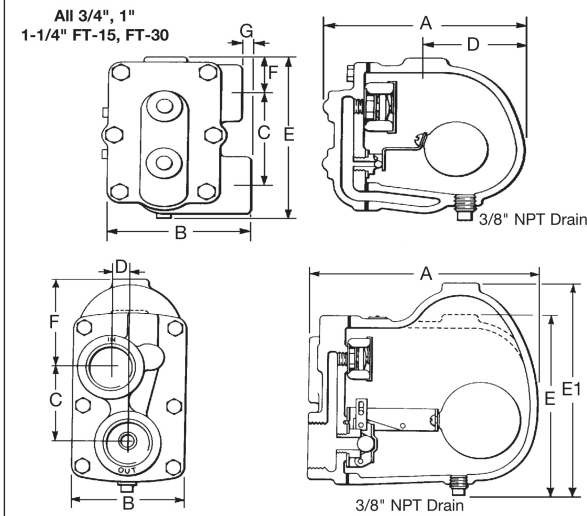

Size	Dimensions (nominal) in inches and millimeters								Weight
	A	B	C	D	E	E1	F	G	
3/4", 1"	6.2 157	4.6 117	3.3 84	3 77	5.75 146	-	1.3 33	0.3 7.9	9 lb 4.1 kg
1 1/4" * 1 1/2"	8.5 216	4.25 108	3 76	0.7 17	-	8.4 213	3.5 89	-	18 lb 8.2 kg
2"	9.8 249	4.9 124	4.9 124	0.12 3	9.1 230	-	1.9 49	-	26 lb 11.8 kg
*1-1/4" FT-15, FT-30	6.2 157	4.7 119	3 76	2.8 72	5.75 146	-	1.5 38	0.3 7.9	9.3 lb 4.2 kg

All 1-1/2", 2"
1-1/4" FT-75, FT-125

Sample Specification

Steam traps shall be of the mechanical ball float type having cast iron bodies, NPT connections, and all stainless steel internals. Incorporated into the trap body shall be a stainless steel balanced pressure thermostatic air vent capable of withstanding up to 450°F(25°C) and resisting waterhammer without sustaining damage. Internals of the trap shall be completely servicable without disturbing the piping.

Installation

A pipeline strainer should be installed ahead of any steam trap. Full port isolating valves should be placed to permit servicing. The trap should be installed below the drainage point of the equipment with a collecting leg before the trap, in a position so that the float arm is in a horizontal plane so that the float rises and falls vertically, and with the direction of flow as indicated on the body. Refer to IM-2-300 for complete instructions.

Maintenance

This product can be maintained without disturbing the piping connections. Complete isolation from both supply and return line is required before any servicing is performed. The trap should be disassembled periodically for inspection and cleaning of the valve head and seat, operating mechanism and air vent. Worn or damaged parts should be replaced using a complete valve mechanism assembly and/or air vent assembly. **Complete installation and maintenance instructions are given in IM-2-300, which accompanies the product.**

Spare Parts

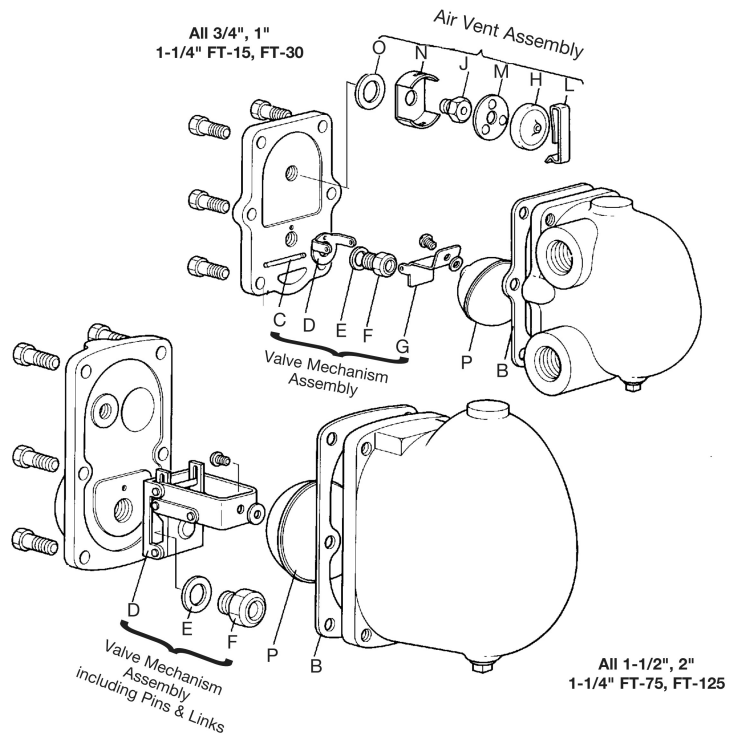

Gasket Kit (3 of each)	B, E
Air Vent Kit	H, J, L, M, N, O
Valve Mechanism Kit (less float)	C, D, E, F, (G)
Float Kit	P
Replacement Module	Consists of: Air Vent Assembly and Valve Mechanism (w/Float) attached to a Cover and supplied with a Cover Gasket, Nameplat and a set of Cover Bolts. (Assembled)
3/4", 1", 1-1/4" FT-15	
3/4", 1", 1-1/4" FT-30	
3/4", 1", FT-15, FT-125	

TI-2-313-US 2.14